

CHARACTERISTICS

**SBM
21 BX**

1

SAFETY

- The whole machine and crawler can be operated by remote control.
- Semi-automatic machine that only needs two men for its operation
- It has a positioning arm and hydraulic wrench that eliminate the direct contact of the operator during the work of coupling and uncoupling of the drill pipes.

2

ENVIRONMENTAL HEALTH

- It is an eco friendly machine that only needs electricity and water or air for its operation.

3

MAXIMUM PRODUCTIVITY

- It is equipped with a chute to protect the machine and deflect the debris.
- Permanently attached to the self-propelled crawler that allows it to be transported from site to site without assistance.
- The SBM 21 BX uses 4 crawler leveling cylinders, 2 erecting cylinders, and 8 pinning cylinders to self-level and secure for drilling.
- No concrete pad needed as standard boxhole machines require.
- Fully integrated power and control system.



TECHNICAL SPECIFICATIONS



CAPACIDADES		MINIMUM	WEIGHT AND DIMENSIONS	
Range of Capacities	Length	295 ft / 90 m	Machine Width	118.0 in / 3,000 mm
	Diameter	30 ft / 0.76 m	Machine Height (Transport)	137.0 in / 3,480 mm
Main Motor Horsepower		100 hp / 75 kW	Workstation Height	191.0 in / 4,850 mm
Reaming Thrust (*)		134,900 lbf / 600 kN	Machine Length	279.0 in / 7,080 mm
Max. Torque		11,000 lbf-ft / 15 kN-m	Weight (**)	57,200 lb / 26,000 kg
Side Dip Angle Adjustment		45° - 135°	Drill Pipe	10 in x 3 ft 254 mm x 0.91 m
CRAWLER SPECIFICATIONS				
Max. Speed	2.0 ft/s / 0.6 m/s	1.4 mph / 2.3 km/h		
Diesel Engine Power @ 2500 rpm	138 hp / 103 kW			
Max. Gradient			15°	

(*) At 5,000 psi (35 Mpa)
 (**) Total weight includes the Pipe Positioner, Crawler, Chute, 21 BX Boxhole reamer with cutters and Pilot Bit.

Note: Specifications may change without notice.

General View

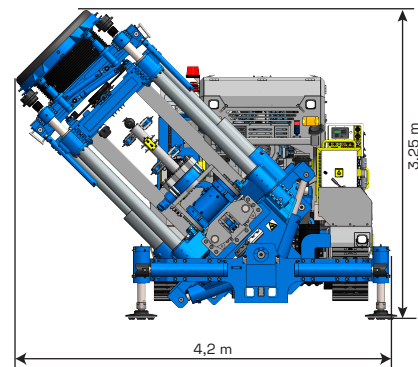
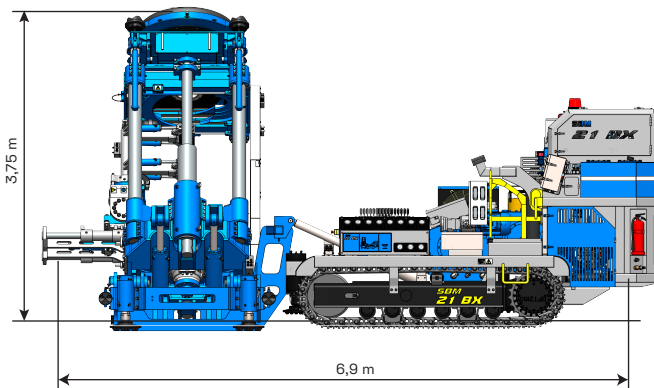
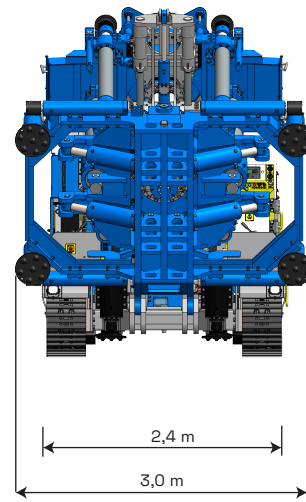
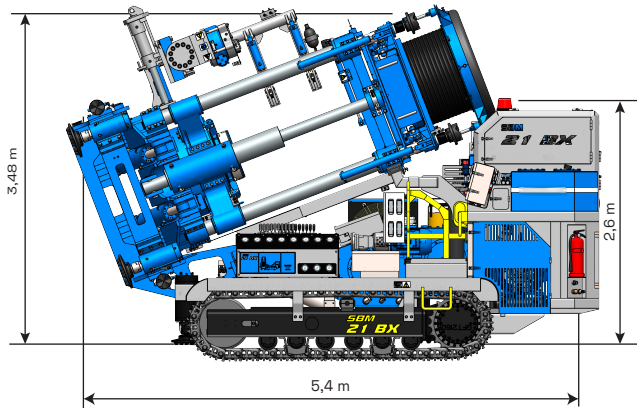

MEXICO

sales.mexico@tumirb.com.mx
 Mobile.: +52 449 196 3210
 Aguascalientes, Aguascalientes

BRAZIL

sales.brasil@tumirb.com.br
 Mobile.: +55 31 97238 9320
 Belo Horizonte, Minas Gerais

PERU

sales.peru@tumirb.com
 Mobile.: +51 982 483 947
 Lima, Lurin

ZAMBIA

sales.zambia@tumirb.com.zm
 Mobile.: +26 076 275 5449
 Kitwe, Copperbelt Province

USA

sales.usa@us-tti.com
 Mobile.: +51 994 823 167
 Houston, Texas